

Tomaszów Lubelski, WWTP

Self-cleaning coarse screen

SCC-HM 950(1000)x3800/900x30/85°

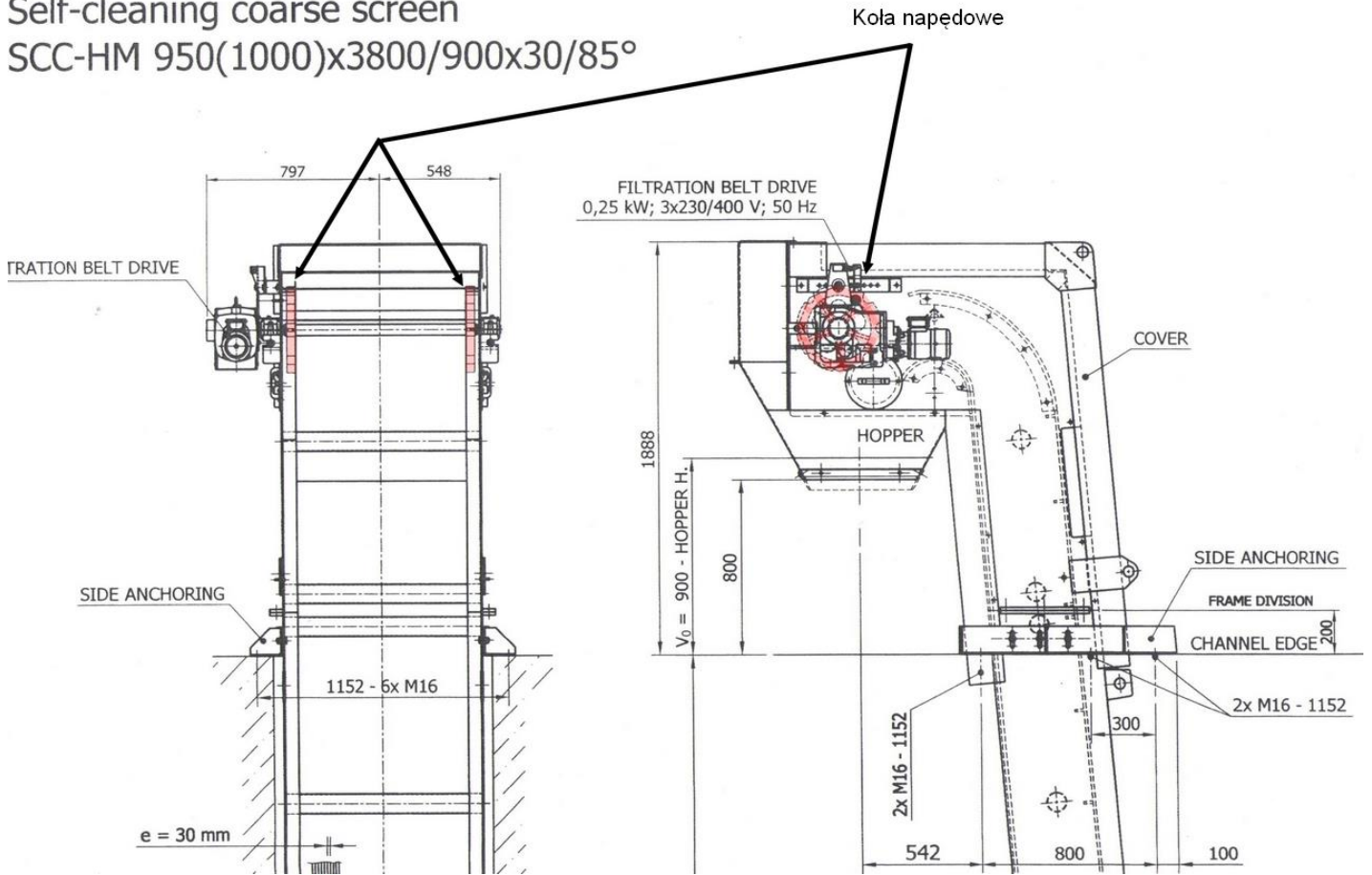

RAKE BELT

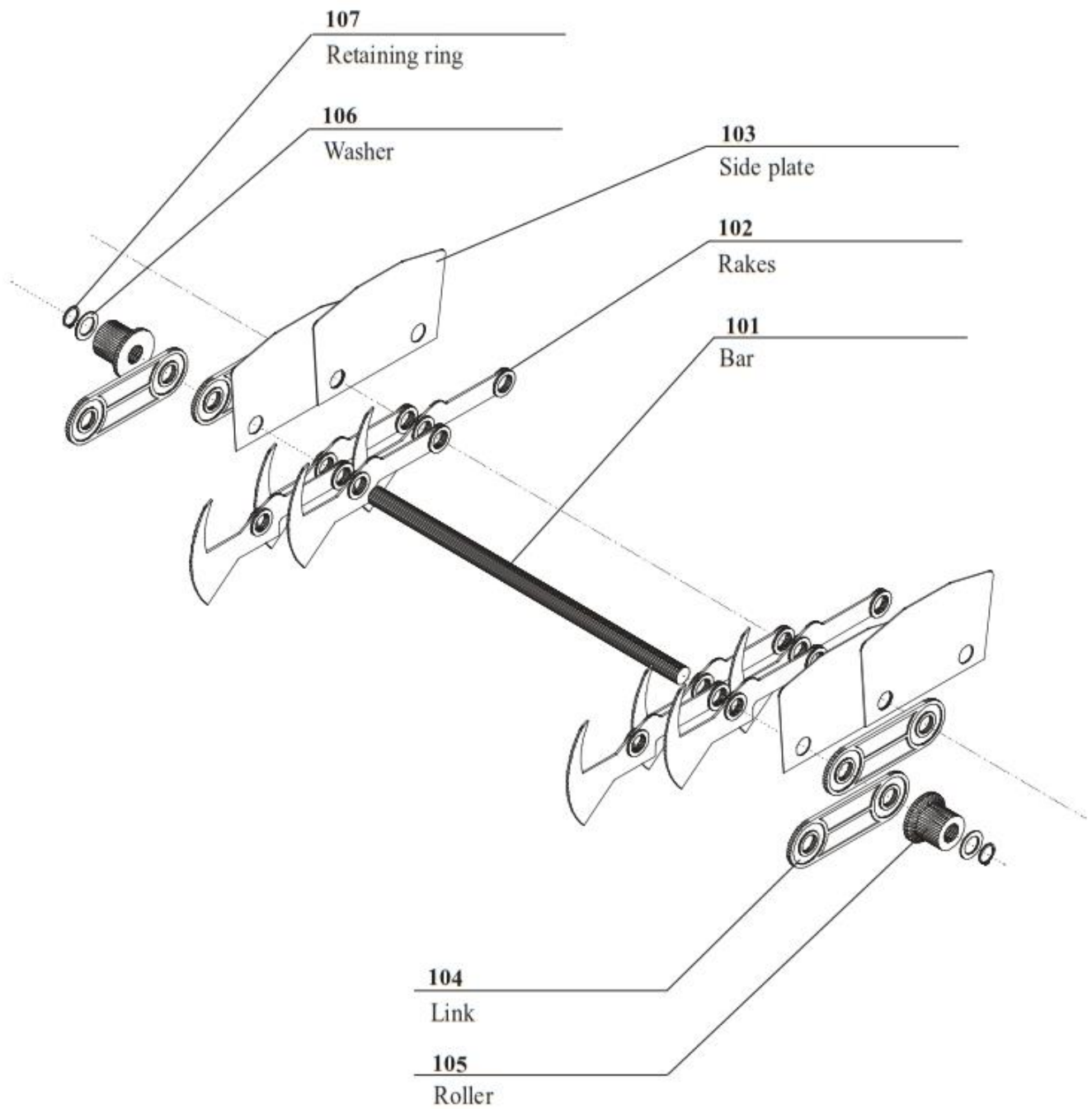

ANCHORING, SUPPORT, GUIDE ARCHES, LIMIT SWITCH HOLDER

